

IWAKI Magnetic Drive Pump

MXM (Europe version: English)

Instruction Manual

 Read this manual before use of product

Thank you for selecting an Iwaki MXM Series Magnetic Drive Pump. This instruction manual deals with "*Safety instructions*", "*Outline*", "*Installation*", "*Operation*", and "*Maintenance*" sections. Please read through this manual carefully to ensure the optimum performance, safety and service of your pump.

Contents

Important instructions	1
Safety instructions	2
<i>Outline</i>	
1. Unpacking & Inspection	5
2. Model codes	6
3. Operating conditions	7
4. Part names	8
<i>Installation</i>	
1. Before installation	13
2. Pipework	14
3. Wiring	16
4. Protection equipment	17
<i>Operation</i>	
1. Before operation	19
2. Operation	20
3. Shutdown	21
<i>Maintenance</i>	
1. Troubleshooting	23
2. Maintenance & Inspection	25
3. Disassembly & Assembly	28
4. Spare & Wear parts	35



This instruction manual should be kept on hand by the end user for quick reference.

Contact us or your nearest dealer if you have any questions.

Important instructions

For the Safe and Correct Handling of the Pump

- "Safety Instruction" section deals with important details about handling of the product. Before use, read this section carefully for the prevention of personnel injury or property damage.
- Observe the instructions accompanied with "WARNING" or "CAUTION" in this manual. These instructions are very important for protecting users from dangerous situations.
- The symbols on this instruction manual have the following meanings:

 WARNING	Nonobservance or misapplication of "Warning" sections could lead to serious accident which may result in death.
 CAUTION	Nonobservance or misapplication of "Caution" sections could lead to personal injury or property damage.

Types of Symbols



Indicates that "Warning" or "Caution" must be exercised. Inside this triangle, a concrete and practical image provided as a warning or caution message is depicted.



Indicates a prohibited action or procedure. Inside or near this circle, a concrete and practical image of the activity to be avoided is depicted.



Indicates an important action or procedure which must be performed or carried out without fail. Failure to follow the instructions herein can lead to malfunction or damage to the pump.

For exportation

Technology related to the use of goods in this instruction manual falls in the category of technology contained in the Foreign Exchange Order Attachment, which includes complementary export control of technology. Please be reminded that export license, which is issued by the Ministry of Economy, Trade, and Industry could be required, when this is exported or provided to someone even in Japan.

Safety instruction

WARNING

● **Access limitation**

The magnet drive pump has a pair of strong magnets (the magnet capsule and drive magnet). The strong magnet field could adversely affect the persons who are assisted by electronic devices such as the pacemaker.



● **Power OFF**

Be sure to turn off power before starting maintenance/repair work. Make sure no one turns on power while working on the pump, otherwise it may result in a serious accident. If your work field is noisy or dark, let other people know about the situation by displaying a notice such as "POWER OFF (Maintenance)" near a power switch.



● **Wear protective clothing**

Always wear protective clothing such as eye protection and protective gloves during pipework or dismantlement of the pump.



● **Lifting pump**

When lifting the pump, apply a chain or belts to the eye bolts to keep the pump horizontal.



● **Do not remodel pump**

Do not remodel the pump. We are not responsible for any personal injury or property damage due to modification.



● **When handling dangerous liquid**

For the transfer of the harmful liquid as mentioned below, be sure to conduct daily inspection and maintenance for the prevention of liquid/gas leakage.



1. Explosive or flammable liquid
2. Corrosive chemicals
3. Harmful liquid or gas

● **Keep good ventilation**

Poisoning may result when handling a toxic or odorous liquid. Install an air fan in order to reduce the possibility of health damage.



Safety instruction

CAUTION

- **Attention to magnetic force**

Strong magnets are used in this pump. Personal injury may be caused from the strong magnetic force. Follow the procedure on "Disassembly & Assembly" when conducting maintenance work.



- **Do not run pump dry**

Running the pump without liquid, friction heat damages the inside of pump. Dry running takes place when starting the pump with a closed suction line.



Prohibited

- **A qualified operator only**

The pump must be handled or operated by a qualified person with a full understanding of the pump.



- **Specified application only**

The use of the pump in any application other than those clearly specified may result in failure or damage.



Prohibited

- **Take countermeasures against static electricity**

When low electric conductivity liquids such as ultra-pure water and fluor inactive liquid (e.g. Fluorinert™) are handled, static electricity may be generated in the pump and may cause static discharge.



- **Conduct degassing before operation**

Always prime the pump and remove air before operation. Note that hydrogen peroxide and sodium hypochlorite easily generate gas and degassing is needed before every operation. Otherwise, sliding parts may be damaged.



- **Countermeasure against efflux**

Take protective measures against an accidental chemical overflow results from pump or piping breakage. Do not soak chemicals into the ground directory.



- **Disposal of the used pump**

Dispose of a used pump in accordance with local laws and regulations (Consult a licensed industrial waste products disposing company.).



Outline

<i>1. Unpacking & Inspection</i>	<i>5</i>
<i>2. Model codes</i>	<i>6</i>
<i>3. Operating conditions</i>	<i>7</i>
<i>4. Part names</i>	<i>8</i>

Outline

1. Unpacking & Inspection

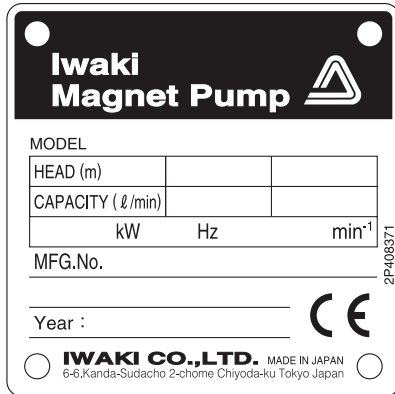

On unpacking the product, check the following points. If you find any problems, contact your nearest distributor.

1. Check the information on nameplate (model code, flow rate, discharge pressure and voltage) to see if the product is delivered as per order.
2. Check for transit damage, deformation, and loose bolts.

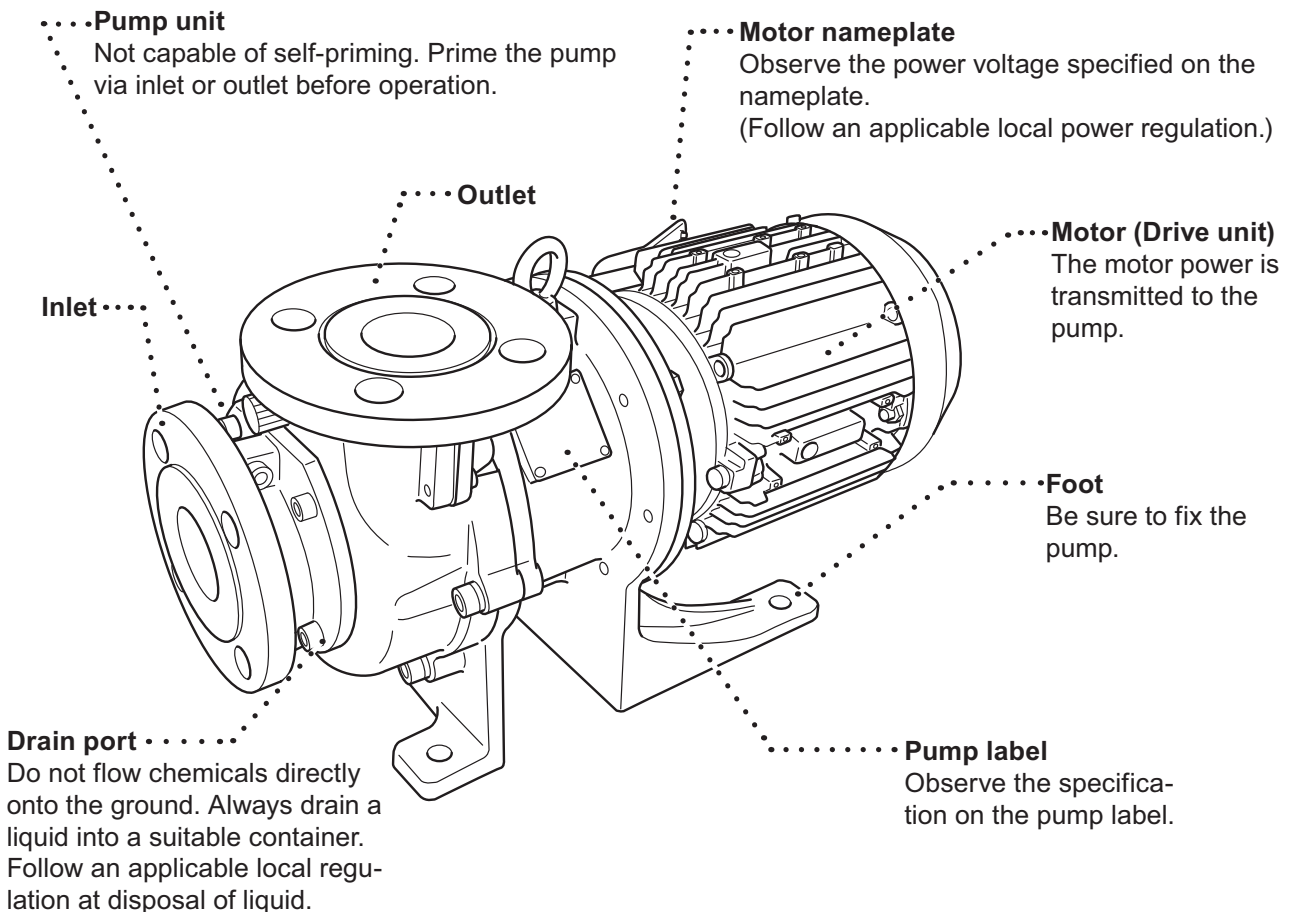

CAUTION

Do not wipe labels or the pump body with a solvent.

Outline

2. Model codes

MXM 54 3 - 150 3 E CF V J - B
a b c d e f g h i

a. Pump bore

Inlet bore × Outlet bore

22: 25A × 25A

44: 40A × 40A

54: 50A × 40A

b. Motor output

0: 0.37kW 1: 0.75kW 2: 1.5kW 3: 2.2kW 5: 4.0kW

c. Impeller diameter

70-150mm

d. Impeller code

1 or 2 MXM22

1 or 2 MXM44

1, 3 or 4 MXM54

e. Wet end material

E: CFRETFE

f. Bearing/spindle material

CF: High density carbon/High purity alumina ceramic

FF: High purity alumina ceramic/High purity alumina ceramic

KK: SiC/SiC

g. O ring material

V: FKM

E: EPDM

A: AFLAS®

P: DAI-EL PERFLUOR®

h. Flange connection/Motor standard

J : JIS flange + JIS motor

I : ISO flange + IEC motor

A : ANSI flange + JIS motor

U : ANSI flange + NEMA motor

i. Special specification

Blank: Standard

B: With base

H: Europe version

S: Special specification

Outline

3. Operating conditions

Maximum operating pressure

Observe the maximum operating pressure below.

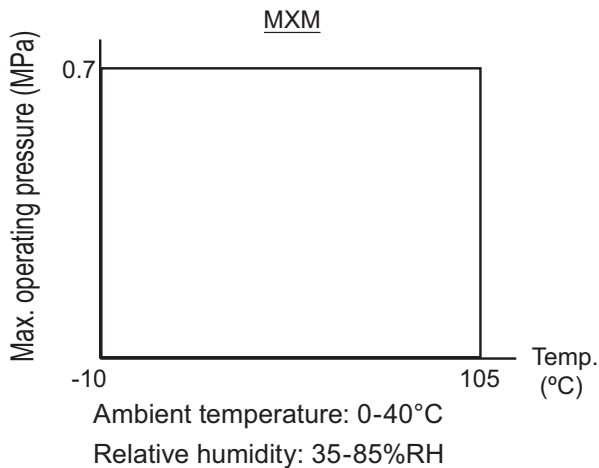

NOTE: The minimum liquid temperature for AFLAS® O ring is 10°C.

Slurry

Generally the pump can not send slurry except the KK type (SiC bearing and SiC spindle).

The KK type can handle slurry up to 5% (concentration), 50µm (particle size) and 80Hs (hardness).

Contact us for details.

Performance change

Shaft power, discharge capacity and pump head vary with specific gravity and viscosity. The pump is designed for a specified liquid. Contact us before changing liquid specification.

Temperature change

Note that viscosity, vapour pressure or corrosiveness changes with liquid temperature. The change is shown in performance such as flow rate while the pump itself is not affected.

The maximum liquid viscosity for the FF type

1 mPa•S (cP) or more

Outline

4. Part names

MXM220H

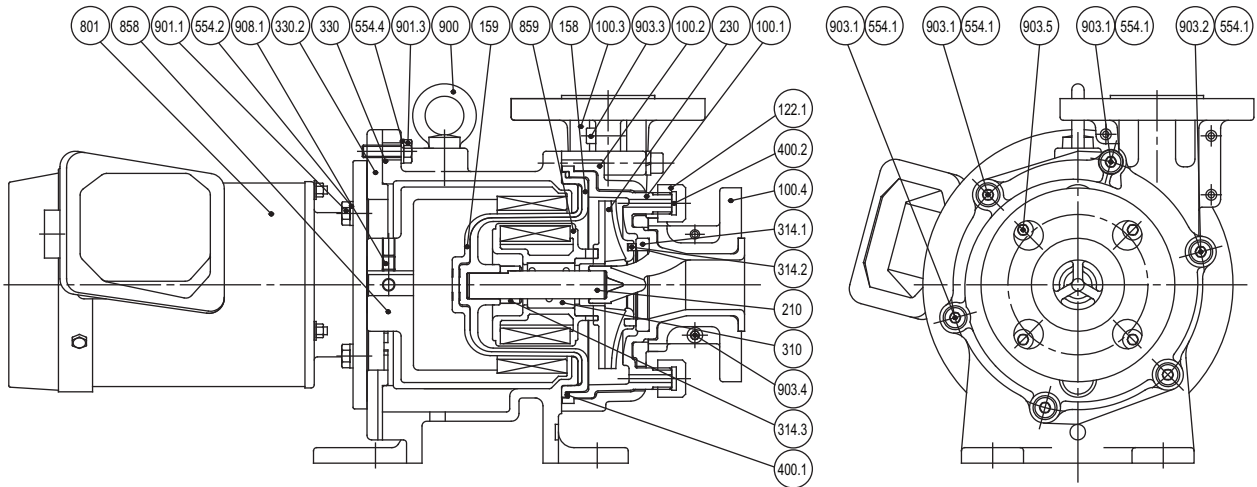

NO.	PART NAMES	Q'TY	MATERIAL	REMARKS	
100.1	FRONT CASING	1	CFRETFE		
100.2	COVER A	1	DUCTILE IRON		
100.3	COVER B	1			
100.4	COVER C	2			
122.1	DRAIN CAP	2	ETFE		
158	REAR CASING	1	CFRETFE		
159	REAR CASING COVER	1	FRP		
230	IMPELLER	1	CFRETFE		
330	FRAME	1	DUCTILE IRON		
330.2	MOTOR ADAPTER	1			
400.1	O RING	1	V: FKM E: EPDM A: AFLAS® P: DAI-EL PERFLUOR®	JIS B 2401 G140	
400.2	GASKET	2			
554.1	SPRING WASHER	6	STNLS STL	M8	
554.2	SPRING WASHER	4			
554.4	SPRING WASHER	4			
801	MOTOR	1		0.37kW	
858	DRIVE MAGNET UNIT	1	FERRITE MAGNET+DUCTILE IRON		
859	MAGNET CAPSULE	1	FERRITE MAGNET+CFRETFE		
900	EYE BOLT	1	STEEL	M10	
901.1	HEX. HEAD BOLT	4	STNLS STL	M8×20	
901.3	HEX. HEAD BOLT	4		M8×25	
903.1	HEX SOCKET HEAD BOLT	3		M8×50	
903.2	HEX SOCKET HEAD BOLT	3		M8×70	
903.3	HEX SOCKET HEAD BOLT	3	STEEL	M6×18	
903.4	HEX SOCKET HEAD BOLT	2			
903.5	HEX SOCKET HEAD BOLT	4	STNLS STL	M8×15 or M8×16	
908.1	HEX SOCKET SET SCREW	2	STEEL		

NO.	PART NAMES	Q'TY	MATERIAL			REMARKS
			CF	FF	KK	
210	SPINDLE	1	HIGH PURITY ALUMINA CERAMIC		SiC	
310	BEARING	1	HIGH DENSITY CARBON	HIGH PURITY ALUMINA CERAMIC	SiC	
314.1	LINER RING	1	HIGH PURITY ALUMINA CERAMIC		SiC	
314.2	MOUTH RING	1	FILLED PTFE		SiC	
314.3	REAR THRUST	1	CFRETFE			

Outline

MXM221H

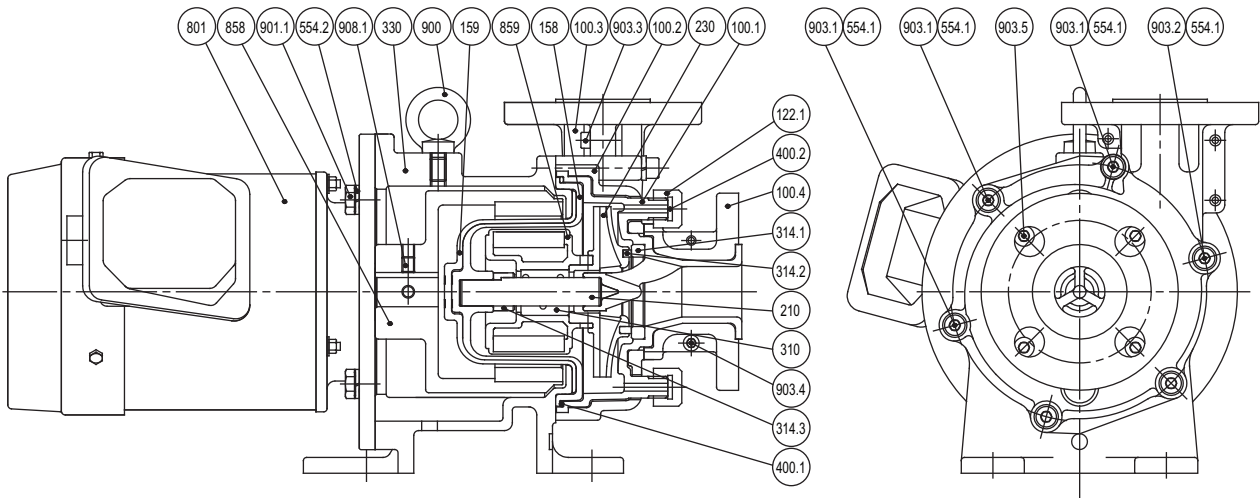

NO.	PART NAMES	Q'TY	MATERIAL	REMARKS
100.1	FRONT CASING	1	CFRETFE	
100.2	COVER A	1	DUCTILE IRON	
100.3	COVER B	1		
100.4	COVER C	2		
122.1	DRAIN CAP	2		ETFE
158	REAR CASING	1	CFRETFE	
159	REAR CASING COVER	1	FRP	
230	IMPELLER	1	CFRETFE	
330	FRAME	1	DUCTILE IRON	
400.1	O RING	1	V: FKM E: EPDM A: AFLAS®	JIS B 2401 G140
400.2	GASKET	2	P: DAI-EL PERFLUOR®	
554.1	SPRING WASHER	6	STNLS STL	M8
554.2	SPRING WASHER	4		M10
801	MOTOR	1		0.75kW
858	DRIVE MAGNET UNIT	1	FERRITE MAGNET+DUCTILE IRON	
859	MAGNET CAPSULE	1	FERRITE MAGNET+CFRETFE	
900	EYE BOLT	1	STEEL	
901.1	HEX. HEAD BOLT	4	STNLS STL	M10×25
903.1	HEX SOCKET HEAD BOLT	3		M8×50
903.2	HEX SOCKET HEAD BOLT	3		M8×70
903.3	HEX SOCKET HEAD BOLT	3	STEEL	M6×18
903.4	HEX SOCKET HEAD BOLT	2		
903.5	HEX SOCKET HEAD BOLT	4	STNLS STL	M8×15 or M8×16
908.1	HEX SOCKET SET SCREW	2	STEEL	

NO.	PART NAMES	Q'TY	MATERIAL			REMARKS
			CF	FF	KK	
210	SPINDLE	1	HIGH PURITY ALUMINA CERAMIC		SiC	
310	BEARING	1	HIGH DENSITY CARBON	HIGH PURITY ALUMINA CERAMIC	SiC	
314.1	LINER RING	1	HIGH PURITY ALUMINA CERAMIC		SiC	
314.2	MOUTH RING	1	FILLED PTFE		SiC	
314.3	REAR THRUST	1	CFRETFE			

Outline

MXM441H/ 442H

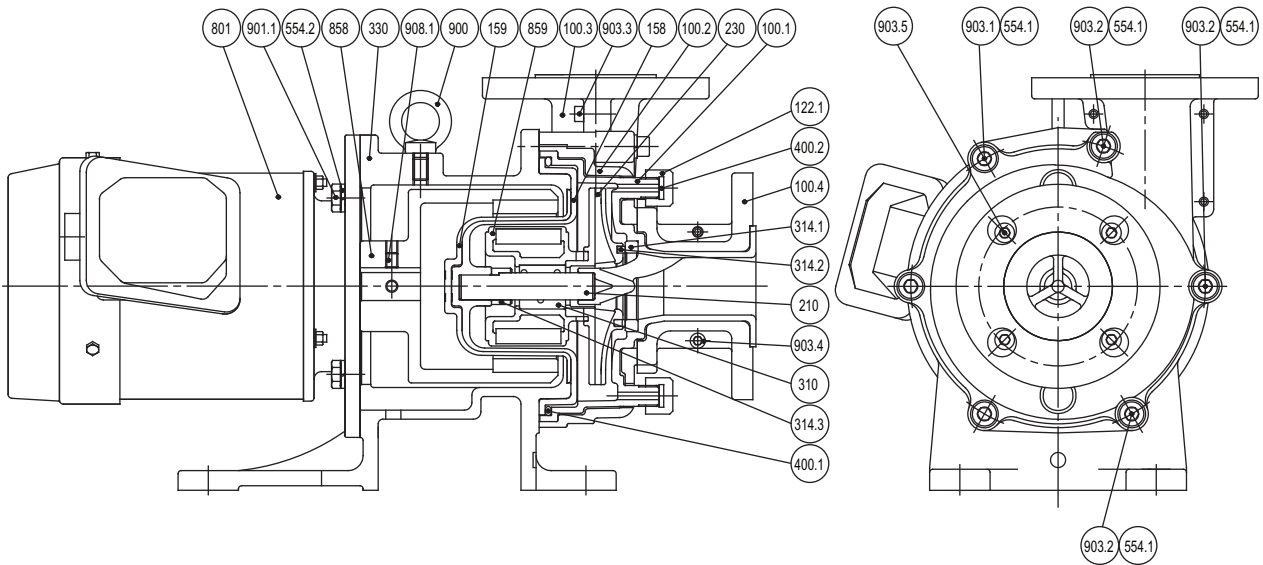

NO.	PART NAMES	Q'TY	MATERIAL		REMARKS
100.1	FRONT CASING	1	CFRETFE		
100.2	COVER A	1	DUCTILE IRON		
100.3	COVER B	1			
100.4	COVER C	2			
122.1	DRAIN CAP	2	ETFE		
158	REAR CASING	1	CFRETFE		
159	REAR CASING COVER	1	FRP		
230	IMPELLER	1	CFRETFE		
330	FRAME	1	DUCTILE IRON		
400.1	O RING	1	V: FKM E: EPDM A: AFLAS® P: DAI-EL PERFLUOR®		JIS B 2401 G160
400.2	GASKET	2			
554.1	SPRING WASHER	6	STNLS STL		M10
554.2	SPRING WASHER	4			M10
801	MOTOR	1			0.75/1.5kW
858	DRIVE MAGNET UNIT	1	0.75kW FERRITE MAGNET+DUCTILE IRON	1.5kW REAR EARTH MAGNET+DUCTILE IRON	
859	MAGNET CAPSULE	1	0.75kW FERRITE MAGNET+CFRETFE	1.5kW REAR EARTH MAGNET+CFRETFE	
900	EYE BOLT	1	STEEL		
901.1	HEX. HEAD BOLT	4	STNLS STL		M10×25
903.1	HEX SOCKET HEAD BOLT	3			M10×55
903.2	HEX SOCKET HEAD BOLT	3			M10×75
903.3	HEX SOCKET HEAD BOLT	3	STEEL		M6×18
903.4	HEX SOCKET HEAD BOLT	2			
903.5	HEX SOCKET HEAD BOLT	4			M8×20
908.1	HEX SOCKET SET SCREW	2	STEEL		

NO.	PART NAMES	Q'TY	MATERIAL			REMARKS
			CF	FF	KK	
210	SPINDLE	1	HIGH PURITY ALUMINA CERAMIC		SiC	
310	BEARING	1	HIGH DENSITY CARBON	HIGH PURITY ALUMINA CERAMIC	SiC	
314.1	LINER RING	1	HIGH PURITY ALUMINA CERAMIC		SiC	
314.2	MOUTH RING	1	FILLED PTFE		SiC	
314.3	REAR THRUST	1	CFRETFE			

Outline

MXM542/ 543/ 545

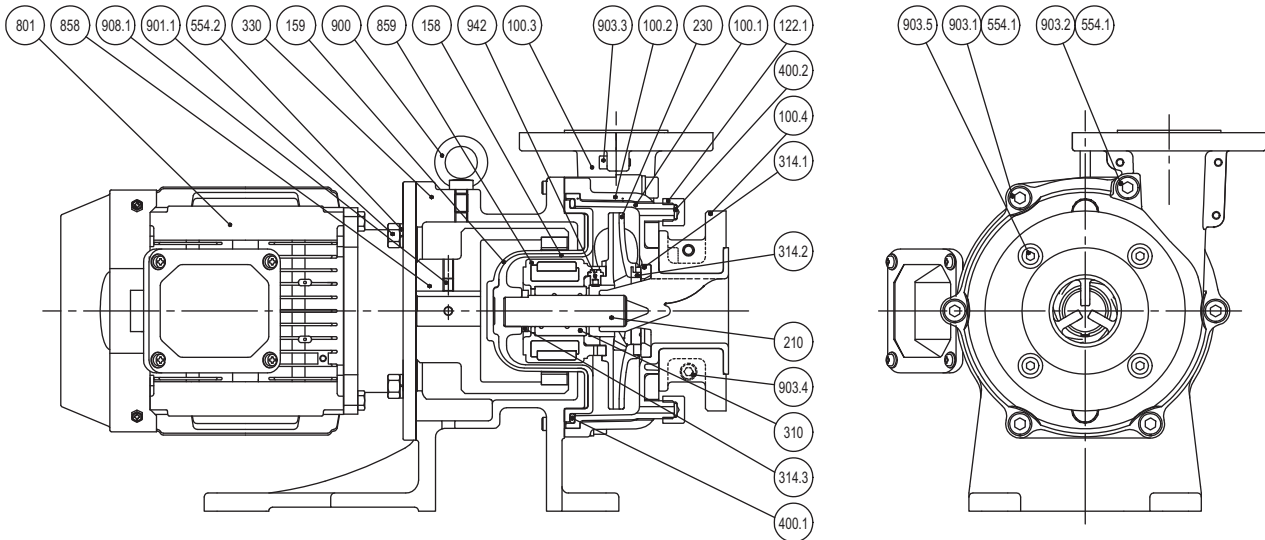

NO.	PART NAMES	Q'TY	MATERIAL	REMARKS
100.1	FRONT CASING	1	CFRETFE	
100.2	COVER A	1	DUCTILE IRON	
100.3	COVER B	1		
100.4	COVER C	2		
122.1	DRAIN CAP	2	ETFE	
158	REAR CASING	1	CFRETFE	
159	REAR CASING COVER	1	FRP	
230	IMPELLER	1	CFRETFE	
330	FRAME	1	DUCTILE IRON	
400.1	O RING	1	V: FKM E: EPDM A: AFLAS® P: DAI-EL PERFLUOR®	JIS B 2401 G165
400.2	GASKET	2		
554.1	SPRING WASHER	6	STNLS STL	M10
554.2	SPRING WASHER	4		1.5/2.2kW: M10 4.0kW: M12
801	MOTOR	1		1.5/2.2/4.0kW
858	DRIVE MAGNET UNIT	1	REAR EARTH MAGNET+DUCTILE IRON	
859	MAGNET CAPSULE	1	REAR EARTH MAGNET+CFRETFE	
900	EYE BOLT	1	STEEL	M10
901.1	HEX. HEAD BOLT	4	STNLS STL	1.5/2.2kW: M10×30 4.0kW: M12×35
903.1	HEX SOCKET HEAD BOLT	5		M10×40
903.2	HEX SOCKET HEAD BOLT	1		M10×80
903.3	HEX SOCKET HEAD BOLT	3	STEEL	M6×18
903.4	HEX SOCKET HEAD BOLT	2		M8×20
903.5	HEX SOCKET HEAD BOLT	4	STNLS STL	M8×15 or M8×16
908.1	HEX SOCKET SET SCREW	1	STEEL	M8×10
942	LOCK PIN	2	CFRETFE	

NO.	PART NAMES	Q'TY	MATERIAL			REMARKS
			CF	FF	KK	
210	SPINDLE	1	HIGH PURITY ALUMINA CERAMIC		SiC	
310	BEARING	1	HIGH DENSITY CARBON	HIGH PURITY ALUMINA CERAMIC	SiC	
314.1	LINER RING	1	HIGH PURITY ALUMINA CERAMIC		SiC	
314.2	MOUTH RING	1	FILLED PTFE		SiC	
314.3	REAR THRUST	1	CFRETFE			

Installation

<i>1. Before installation</i>	<i>13</i>
<i>2. Pipework</i>	<i>14</i>
<i>3. Wiring</i>	<i>16</i>
<i>4. Protection equipment.....</i>	<i>17</i>

Installation

1. Before installation

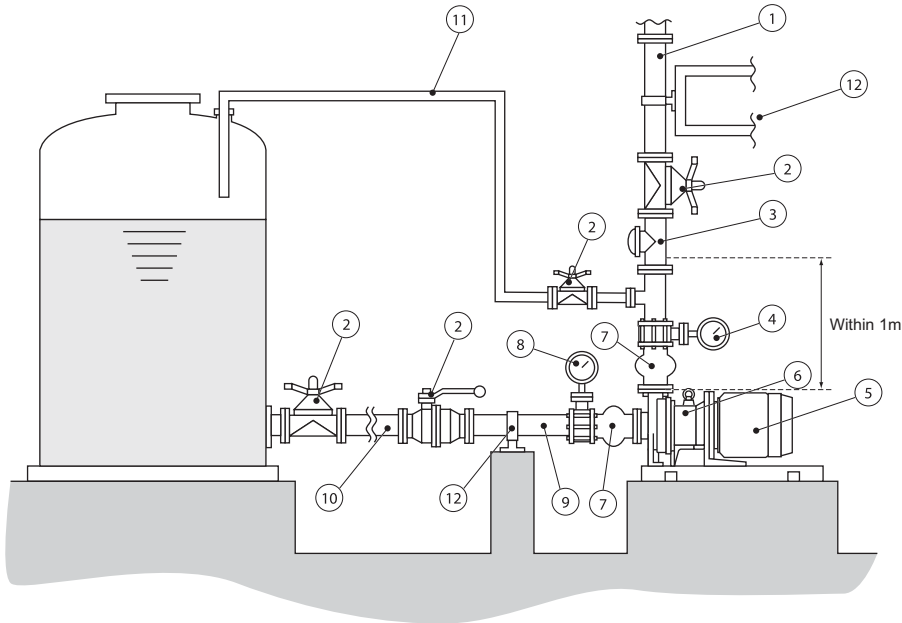

1. Discharge line
2. Gate valve
3. Check valve
4. Pressure gauge
5. Motor
6. Magnetic drive pump
7. Expansion joint
8. Vacuum (compound) gauge
9. Straight suction line
10. Suction line
11. Air vent line
12. Pipe support

Piping layout

■ Installation location

1. Select a flat and sound foundation where is free from vibration
2. Keep a work space wide enough for motor removal (back pull out), assembly or dismantlement.
3. The foundation should be larger than a pump base footprint.

■ Pump position

1. Install the pump as close to a supply tank and under flooded suction application.
2. In the suction lift application, arrange the auxiliary line for priming and mount a foot valve at the suction pipe end.

■ Foundation work

1. See the diagram and instructions below as necessary.
2. For the pump without the base plate, do not mount the foot in the foundation. Otherwise, the pump can not be dismantled.

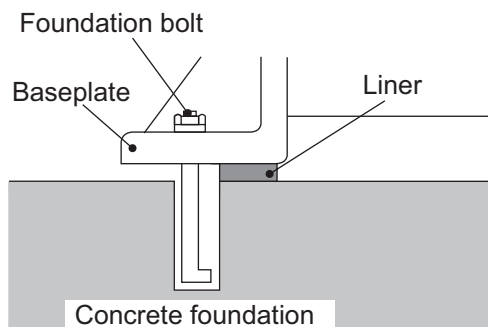

Installation

2. Pipework

■ Tightening torque between the pump and pipework

Connect the pump to pipework via inlet and outlet flanges according to the tightening torque below. Tighten bolts diagonally at even tension.

Model	Bolt size	Tightening torque
MXM22/44/54	M16	79N•m

NOTE1: The table is based on use of metal pipe flanges with rubber gaskets.

NOTE2: Select the best bolt length so as not to come in contact with the pump.

■ Piping load and momentum

Try not to apply heavy load to the pump inlet and outlet flanges. Permissible piping weight and moment to the pump are as below.

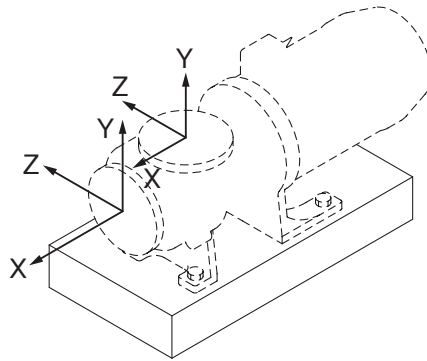

Permissible stress to inlet & outlet flanges

Load direction	Load kN	
	Discharge flange	Suction flange
F _x	0.71	0.89
F _y (compression/tension)	0.89/0.44	0.58
F _z	0.58	0.71

Permissible moments to inlet & outlet flanges

Load direction	Moment kN•m	
	Discharge flange	Suction flange
M _x	0.35	0.46
M _y	0.46	0.35
M _z	0.23	0.23

Installation

■ Suction line

1. *Flooded suction application*

Always realize the flooded suction.

2. *Suction line bore*

A suction line bore should be equal to or larger than pump inlet.

3. *Shortest line length*

Keep the shortest length with the minimum number of bends.

4. *Straight line length*

A suction line should be laid on straight at least for 500mm from the pump inlet.

For easy pump removal and maintenance, install a removable pipe of 300mm in the straight line.

5. *Air pocket*

Do not make any projection or arched line where air may be trapped.

A suction line should be laid with a rising gradient of 1/100 toward the pump.

6. *Use of the eccentric reducer*

If the pump inlet bore is different from that of suction pipe, use the eccentric reducer. Upper side should always be level. Air may be trapped if it is mounted upside down.

7. *Gate valve installation*

In flooded suction application, always install a gate valve on a suction line for overhaul & inspection.

8. *Flushing line*

Lay on a flushing line for cleaning the pump when handling a harmful liquid.

9. *Suction line end*

The suction line end should always be at least 500mm lower than a liquid level for the prevention of entrained air.

10. *In suction lift application*

- The distance between the end of a suction line and the bottom of a supply tank should be 1 to 1.5 times wider than the suction line bore.
- Be sure to install a foot valve or a check valve on a suction line.

11. *Piping support*

Use metal supports so that the pump is not subject to piping weight or thermal stress.

12. *Connections*

Each connection must be completely sealed so that air can not be entrained. Otherwise, a poor flow or the seizure of bushing may result.

Installation

■ Discharge line

1. Discharge line bore

When a discharge line is long but its bore is equal to the pump outlet bore, the specified performance may not be obtained because pipe resistance becomes high. Calculate pipe resistance in advance to decide a discharge line bore.

2. Gate valve installation

Install a gate valve on a discharge line to adjust flow rate and protect the motor from overload. Install check valve as necessary, the optimum installation order is : Pump → Check valve → Gate valve.

3. Discharge valve installation

A discharge valve should be positioned about 1m away from the pump. An air vent line should be mounted near the valve in order to prevent air from remaining.

4. Pressure gauge

Install a pressure gauge on a discharge line to check a discharge capacity and delivery head.

5. Check valve

Install a check valve in the following cases.

- Discharge line is longer than 15m.
- A delivery head is higher than 15m.
- The distance between a liquid level in a supply tank and the top end of a discharge line is 9m or longer.
- Two pumps run in parallel.

6. Air vent line

Lay on an air vent line on a discharge line when the horizontal line length is longer than 15m or more.

7. Drain

Install a drain valve as necessary (to prevent liquid from freezing in the pump, etc.).

8. Piping support

Use metal supports so that the pump is not subject to piping weight or thermal stress.

9. Priming line

Lay on a priming line on a discharge line in suction lift application.

3. Wiring

Electrical works or wiring must be carried out by a qualified person according to local laws or regulations.

- Use the electromagnetic switch which conforms to the motor specifications of voltage and capacity etc.
- When installing the pump out of doors, take a measure to prevent rain water from getting into the switch.
- Install the electromagnetic or the push-button switch apart from the pump.

*See the instruction manual of the motor manufacturer for the motor detail.

Installation

4. Protection equipment

It is recommended to install the following monitoring devices in order to protect the pump.

1. Current sensor/ Power sensor The sensors monitor the motor load and stop the pump on the detection of load change, giving an alarm.
2. Pressure sensor The sensor monitors the starting pressure and stops the pump on the detection of pressure change, giving an alarm.
3. Flow sensor The sensor monitors the discharge flow and stops the pump on the detection of flow change, giving an alarm.
4. Level sensor The sensor monitors the liquid level in the tank and stops the pump when it falls below the specified level, giving an alarm.

It is recommended to install two or more monitoring devices. The more monitoring devices, the more possibility of protecting the pump.

The DR series dry running protector (electric current sensing type) is also available as an option. Contact us for detail.

OPERATION

1. <i>Before operation</i>	19
2. <i>Operation</i>	20
3. <i>Shutdown</i>	21

Operation

1. Before operation

CAUTION

- Never run pump dry or shut off a suction valve during operation. Otherwise, the pump fails in a short period. Especially for the FF types, the bearing and spindle can be damaged in a quite-short time of about one minute.
- Check the rotational direction of the pump. Clockwise seen from the motor end is a correct direction. Operation in the reverse direction may cause pump damage.
- Stop the pump within one minute if cavitation occurs. Do not continue operation with entrained air. Especially for the FF types, the bearing and spindle can be damaged in a quite-short time of about one minute.
- Stop the pump immediately when the magnet coupling is disconnected. The magnet force reduces if the pump keeps on running for one minute or longer in this condition.
- Keep liquid temperature change within 80°C through operation and stopping. Retighten the drain cap when the surrounding or liquid temperature significantly changes. The maximum number of ON-OFF operation should be within six times an hour. Frequent ON-OFF operation can reduce the pump life.
- Start the pump with a closed discharge valve in order to avoid water hammer.
- Closed-discharge operation should be within one minute. If the pump runs with a discharge valve closed for a long time, the liquid temperature inside the pump rises and it damages the pump.
- If power is interrupted when the pump is running, switch off and close a discharge valve.
- Take extra care so that the discharge pressure does not exceed the pump limit. See page 7 for the maximum operating pressure.
- Risk of burning. Pump and pipe surface temperature rise high along with liquid temperature. Do not touch the pump or pipe surface directly in or right after operation.



Model	Liquid temperature	Possible highest surface temperature (at ambient 40°C)
MXM220/221	105°C	80°C
MXM441/442		
MXM542/543/545		85°C

- The noise level is shown below. In case the pump noise affects human health or communication to secure a safety, provide a noise reduction cover.

Model	Noise level
MXM220/221	80dB
MXM441/442	
MXM542/543/545	

Operation

2. Operation

1. Fully close a discharge valve and fully open a suction valve.

2. Prime the pump.

- If the pump is in the flooded suction application, fully open both discharge and suction valves.
- If the pump is in the suction lift application, prime a suction line as well as the pump.

3. Check rotating direction of the motor.

- Close a discharge valve. Power the motor for a quick moment (within a second) in order to check the rotation direction. A correct direction is shown with an "arrow" mark on the pump (Clockwise seen from motor fan side).
- Check if the motor fan smoothly stops when turning off power.

NOTE: If the motor does not stop smoothly, check rotating parts.

4. Air elimination

- Before full-scale operation, eliminate the air in the pump.
- Fully open an air vent line. Run the pump for one second and repeat it 3 to 5 times for air elimination.
- After the air elimination, fully close a discharge valve.

NOTE: In case air vent line is not equipped, repeat the momentary run several times with a discharge valve open.

5. Full-scale operation

- Start the pump with a discharge valve fully closed.

NOTE: Stop the closed-discharge operation within one minute.

- Check that discharge pressure rises to the shut off pressure.
- Gradually open discharge valve to obtain the specified pressure (capacity).

NOTE: Pay attention to the over-load caused by an excessively opened valve.

Precautions on operation

1. When the pump keeps running in negative rotation, the pump breaks.

2. Closed-discharge operation should be stopped within one minute.

3. Observe the minimum flow rate. Otherwise, friction heat may build up and damage the bearing and sliding parts.

MXM220/221/441/442		MXM542/543/545	
Impeller code	Min flow rate	Impeller code	Min flow rate
1, 2	10L/m	1, 3	20L/m
		4	50L/m

*See page 6 "**2. Model codes**".

Operation

3. Shutdown

1. *Slowly close a discharge valve.*

Quick closing by a solenoid valve may cause water hammer and damage the pump. Be sure to slowly close any discharge valve.

2. *Switch off and stop the pump.*

Check that the pump stops smoothly. If the pump stops roughly, make an inspection.

NOTE: When leave the pump stopped for a long period...

Take a countermeasure against freezing in the pump and piping or

In case a blackout has interrupted operation, switch off the pump and close a discharge line.

Maintenance

<i>1. Troubleshooting</i>	<i>23</i>
<i>2. Maintenance & Inspection.....</i>	<i>25</i>
<i>3. Disassembly & Assembly.....</i>	<i>28</i>
<i>4. Spare & Wear parts</i>	<i>35</i>

Maintenance

1. Troubleshooting

Turn off power to stop operation upon sensing abnormalities. And then look for a root cause or contact us as necessary.

Troubles	Symptom		Cause	Point to be checked & Countermeasures
	When a discharge valve is closed.	When a discharge valve is opened.		
Liquid can not be discharged.		The readings of pressure/vacuum gauges drop to zero.	<ul style="list-style-type: none"> Priming liquid level is too low. Dry running 	<ul style="list-style-type: none"> Stop and prime the pump and resume operation. Dismantle and inspect the pump.
	The pump can not be primed.		<ul style="list-style-type: none"> The foot valve malfunction due to foreign matter clogging. 	<ul style="list-style-type: none"> Clean the foot valve.
	After starting, the pressure drops as a discharge valve is opened.	The readings of pressure/vacuum gauges fluctuate and drops to zero.	<ul style="list-style-type: none"> Air ingress through a suction line or a connection. 	<ul style="list-style-type: none"> Check if suction line connections are completely sealed. Check if liquid level in supply tank is not too low.
			<ul style="list-style-type: none"> Disconnection of the magnet coupling 	<ul style="list-style-type: none"> Check if the motor is not overloaded by checking amperage. Check if foreign matters do not lock the impeller or magnet capsule. Check if voltage is normal.
The pressure gauge keeps showing a low pressure.		<ul style="list-style-type: none"> Low pump speed The pump rotates in reverse. 	<ul style="list-style-type: none"> Check wiring or motor. Interchange motor wiring. 	
Discharge capacity is too low.	Pressure & vacuum are normal.	Vacuum is high.	<ul style="list-style-type: none"> The strainer is clogged with foreign matters. 	<ul style="list-style-type: none"> Remove foreign matters.
		Vacuum is very high.	<ul style="list-style-type: none"> Air pocket in suction line 	<ul style="list-style-type: none"> Check and correct suction line.
			<ul style="list-style-type: none"> Foreign matters are clogged at impeller inlet. 	<ul style="list-style-type: none"> Remove foreign matters.
		The readings of pressure gauge & vacuum gauge fluctuate.	<ul style="list-style-type: none"> Air ingress from a suction line or a connection. 	<ul style="list-style-type: none"> Check suction line connections and retighten as necessary.
			<ul style="list-style-type: none"> The pump or discharge line clogs with foreign matters. 	<ul style="list-style-type: none"> Remove foreign matters or scales.
		Vacuum is high but pressure is normal.	<ul style="list-style-type: none"> Resistance such as air pocket in suction line. 	<ul style="list-style-type: none"> Check if there is no arched pipework.
	Vacuum is normal but pressure is high.	<ul style="list-style-type: none"> Actual delivery head is too high or pipe resistance is too large. 	<ul style="list-style-type: none"> Check actual delivery head and pipe resistance. 	
Pressure is low and vacuum is very low.	Both pressure and vacuum are low.	<ul style="list-style-type: none"> The motor rotates in reverse. 	<ul style="list-style-type: none"> Interchange motor wiring. 	

Maintenance

Troubles	Symptom		Cause	Point to be checked & Countermeasures
	When a discharge valve is closed.	When a discharge valve is opened.		
The motor is overheated.			<ul style="list-style-type: none"> • Voltage has dropped greatly. • Overload • Surrounding temperature is too high. 	<ul style="list-style-type: none"> • Check voltage or frequency. • Check specific gravity and viscosity of liquid. • Keep a good ventilation.
A flow rate has dropped suddenly.		Vacuum is high.	<ul style="list-style-type: none"> • A suction line clogs with foreign matters. 	<ul style="list-style-type: none"> • Remove foreign matters.
The pump vibrates.			<ul style="list-style-type: none"> • The base is not anchored firmly. • Anchor bolts are loose. • Cavitation occurs. • Pump bearing is worn or failed. • Magnet capsule or impeller is broken. • Dynamic balance of drive magnet is upset. • Motor bearing is worn. 	<ul style="list-style-type: none"> • Fix the base. • Retighten the bolts. • Remove the cause of cavitation. • Replace as necessary. • Replace as necessary. • Investigate problems and replace as necessary. • Replace bearing or a motor unit.

Maintenance

2. Maintenance & Inspection

WARNING

- **Access limitation**

The magnet drive pump has a pair of strong magnets. The strong magnet field could adversely affect the persons who are assisted by electronic devices such as the pace-maker.

- **Do not catch the finger**

The magnet force of the pump is powerful. Take care not to catch the finger in the bracket.

- **Wear protective clothing**

Coming in contact with a harmful chemical liquid may cause eye or skin trouble. Wear protective clothing such as a protective mask, goggles, gloves during work.

- **Turn off power during maintenance work**

Risk of electrical shock. Make sure a power source is turned off, and the pump and devices are stopped prior to work.

■ **Daily inspection**

1. *Always check for leakage before pump operation. Do not run the pump when liquid leaks. Check if the drain cap is tight. Retighten as necessary.*
2. *Check whether the pump runs without abnormal noise or vibration.*
3. *Check a liquid level in a supply tank and a suction pressure.*
4. *Check that discharge capacity and a motor current value are as per specifications on the nameplate during operation.*

NOTE A discharge pressure is in proportion to the specific gravity of liquid. The cock of the pressure gauge or vacuum gauge should be opened only when measurement is carried out. Close it right after measurement. If the cock remains open during pump operation, the meter mechanism may be adversely affected by the abnormal pressure rise caused by water hammer action.

5. *If a spare pump is stored, run it from time to time to keep it ready for operation at any time when needed.*
6. *Check discharge pressure, discharge capacity, and motor power supply voltage to see if they do not fluctuate during operation. See page 23 "1. Troubleshooting" as necessary.*

Maintenance

■ Periodic inspection

To ensure efficient and smooth operation, perform periodic inspection. Be careful not to damage internal sliding parts and plastic parts when dismantling the pump.

The magnetic force of the drive magnet unit and magnet capsule assembly is strong. **Be careful not to catch the finger. Do not put electrical devices such as a watch and mag card close to the magnets.**

Interval	Part names	Inspection items	Measures
Every six months (Maintain an inspection record)	(Drive magnet unit) Drive magnet Hex. socket set screw	<ul style="list-style-type: none"> ● Wear trace ● If the drive magnet is correctly mounted by hex. socket set screws and they are not loose. ● Decentering of magnet and motor shaft (Max.1/10mm) 	<ul style="list-style-type: none"> ○ Finding wear trace, contact us. ○ Reset the drive magnet to the motor shaft and retighten the screws. ○ Retighten the hex. socket set screws or replace the drive magnet (Contact us).
	Rear casing Rear thrust	<ul style="list-style-type: none"> ● Wear tracks on an inner surface ● Cracks ● Rear thrust wear degree ● Spindle end wear degree ● Contamination in rear casing 	<ul style="list-style-type: none"> ○ Contact us. ○ Replace as necessary. ○ Contact us. ○ Replace as necessary. ○ Remove contamination.
	(Magnet capsule assembly) Magnet capsule Bearing	<ul style="list-style-type: none"> ● Wear tracks on the rear end or side face of the magnet capsule ● Cracks on the rear end or side face of the magnet capsule ● Bearing wear degree ● Loose fit of the impeller unit 	<ul style="list-style-type: none"> ○ Contact us. ○ Contact us. ○ Replace as necessary. ○ Replace or contact us.
	(Impeller unit) Impeller Mouth ring	<ul style="list-style-type: none"> ● Mouth ring wear degree ● Cracks ● Evidence of cavitation (Wear or seizing on the mouth ring.) ● Contamination in the impeller ● Impeller deformation 	<ul style="list-style-type: none"> ○ Replace as necessary. ○ Replace as necessary. ○ Remove the cause of cavitation. ○ Remove contamination. ○ Replace as necessary.
	Front case Rear case Liner ring	<ul style="list-style-type: none"> ● Contamination ● Cracks ● Wear degree, cracks and wear tracks on liner ring ● Drain port clogging ● Swelling or a crack on O ring ● Wear tracks on an unlikely portion 	<ul style="list-style-type: none"> ○ Remove contamination. ○ Replace as necessary. ○ Contact us. ○ Remove clogging ○ Replace as necessary. ○ Contact us.
	Spindle	<ul style="list-style-type: none"> ● Cracks ● Wear degree 	<ul style="list-style-type: none"> ○ Replace as necessary. ○ Replace as necessary.
	Drain cap	<ul style="list-style-type: none"> ● Loose fit 	<ul style="list-style-type: none"> ○ Retighten the cap.

Maintenance

■ Wear limits of bearing and spindle

*If the clearance between the inner diameter of the bearing and the outer diameter of the spindle exceeds 1 mm, either the bearing or spindle, whichever has greater wear, should be replaced regardless of the wear limit. For the ceramic bearing (FF) type, replace the bearing and spindle at the same time.

*Sliding parts may suffer initial wear in an initial operation phase. Note that this is not abnormal.

Model	MXM220/ 221/ 441/ 442		MXM542/ 543/ 545	
	Before use	Wear limit	Before use	Wear limit
Inner diameter of bearing	18mm	19mm	24mm	25mm
Outer diameter of spindle	18mm	17mm	24mm	23mm

See page 32 for bearing replacement.

See page 30 for spindle replacement.

■ Wear limit of mouth ring

The mouth ring is 2 mm forward from the impeller when shipped. Before the step has reduced to 0 mm, replace the mouth ring with new one.

Model	MXM220/ 221/ 441/ 442/ 542/ 543/ 545
Before use	7.5mm
Wear limit	5.5mm

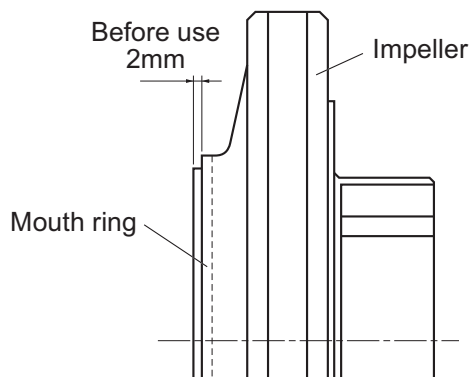

Mouth ring replacement

1. Heat the lugs on the mouth ring by a plastic welder or industrial dryer and open the lugs up to remove the mouth ring.
2. Heat the lugs on the mouth ring by a plastic welder or industrial dryer and then close the lugs down.

Maintenance

3. Disassembly & Assembly

WARNING

- **Access limitation**

The magnet drive pump has a pair of strong magnets. The strong magnet field could adversely affect the persons who are assisted by electronic devices such as the pace-maker.

- **Do not catch the finger**

The magnet force of the pump is powerful. Take care not to catch the finger in the bracket.

- **Wear protective clothing**

Coming in contact with a harmful chemical liquid may cause eye or skin trouble. Wear protective clothing such as a protective mask, goggles, gloves during work.

- **Turn off power during maintenance work**

Risk of electrical shock. Make sure a power source is turned off, and the pump and devices are stopped prior to work.

CAUTION

- **Pay attention to magnet force**

The magnet force is powerful. Take care so that iron pieces and iron powder do not stick to the magnet of pump.

- The powerful magnet force can break the data of the magnetic card, disc or so. Do not have the magnetic product close to the magnet of pump.

Maintenance

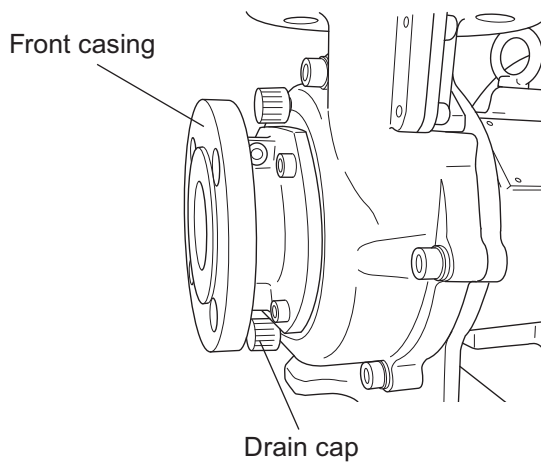

■ Dismantlement

1. Flush out chemical liquid from the pump by a flushing line. Then remove the drain cap to empty the pump.

⚠ WARNING

Wear protective clothing such as goggles, rubber gloves, etc. during maintenance. Coming in contact with a harmful chemical liquid may cause eye or skin trouble.

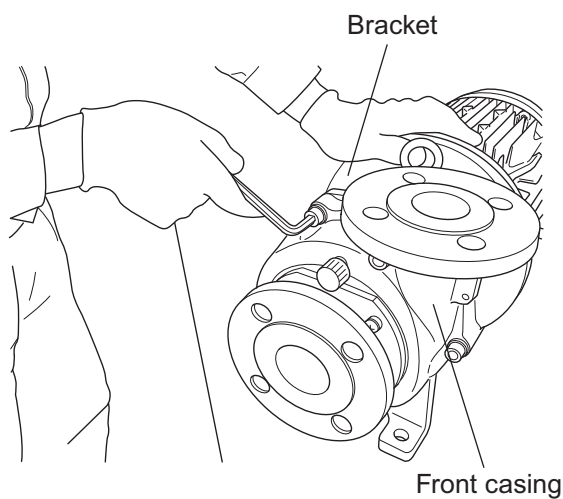

2. Remove hex. socket head bolts from the front casing to remove it from a bracket. Try to pull out the front casing straight from the bracket so as not to damage the spindle in it. The spindle may stay in the front casing after removal. In this case, take care not to loose the rear thrust.

⚠ CAUTION

A strong impact may crack the front casing. Be careful not to hit it.

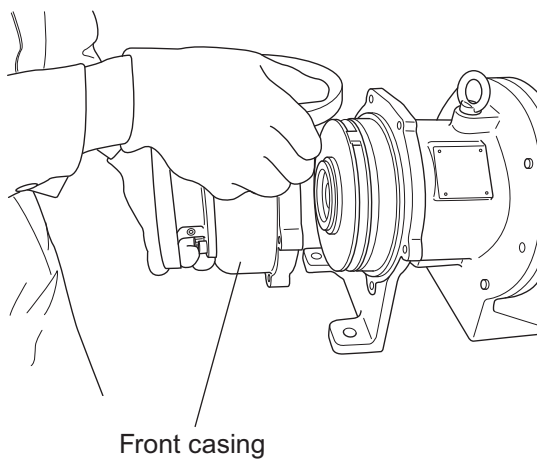

Maintenance

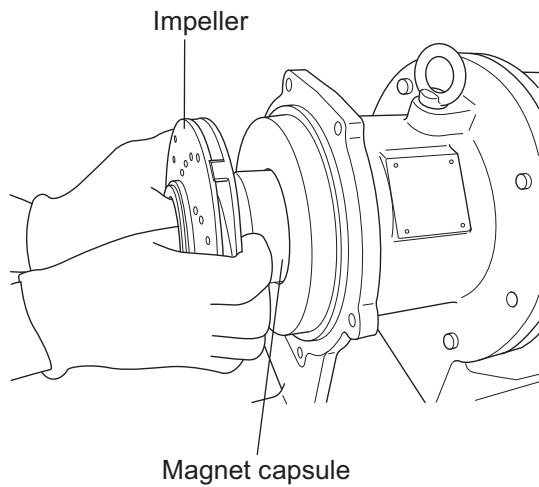

3. Pull out the impeller unit + the magnet capsule assembly. Be careful not to scratch each part. Note that the magnetic force of the magnet capsule assembly is strong. Keep it free from metal pieces or powder. Do not scratch any sliding or sealing surfaces.

CAUTION

The magnetic force of the magnet capsule assembly is powerful. Be careful not to catch the finger in the impeller unit and the assembly.

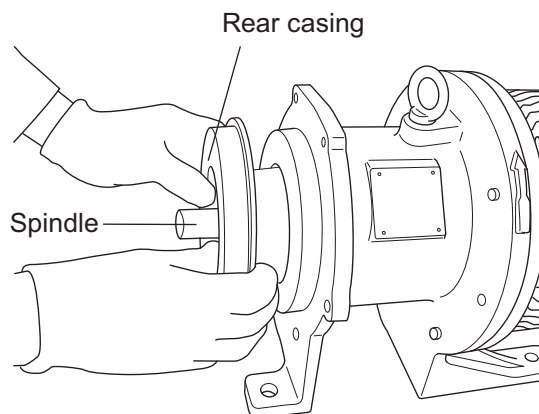

4. Insert a flat-head screwdriver between the rear casing and the motor bracket. And then pull the rear casing forward while lifting it slightly up. If the spindle stays on the front casing, remove it from the front casing. Fit the spindle to the rear casing with the rear thrust mated at the end. Always check the rear thrust is mated to the spindle before fitting spindle. If the spindle can not be removed, warm a spindle connection with hot water (about 90°C) for 5 minutes and try again. Be careful not to be scalded.

CAUTION

Be careful not to damage the sealing surface between the front casing and rear casing where crushes the O ring.

Maintenance

5. Detach the impeller unit from the magnet capsule assembly as necessary. Be careful not to damage the units.

a. MXM220/ 221/ 441/ 442

Slightly tap the back of impeller unit by plastics hammer while holding the magnet capsule assembly. If it is hard to remove, warm them in hot water (about 90°C) for 5 minutes.

Take care not to burn yourself.

b. MXM542/ 543 /545

The impeller unit can not be separated from the magnet capsule assembly unless the lock pins are removed. Do not have an strong impact to the impeller unit before removing the pins.

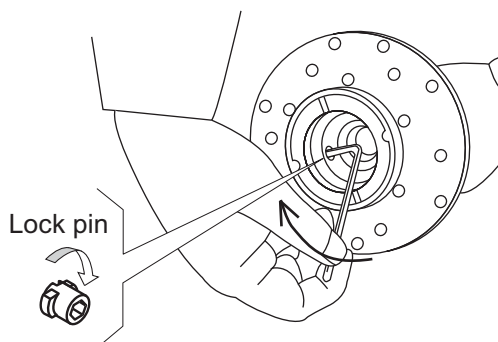
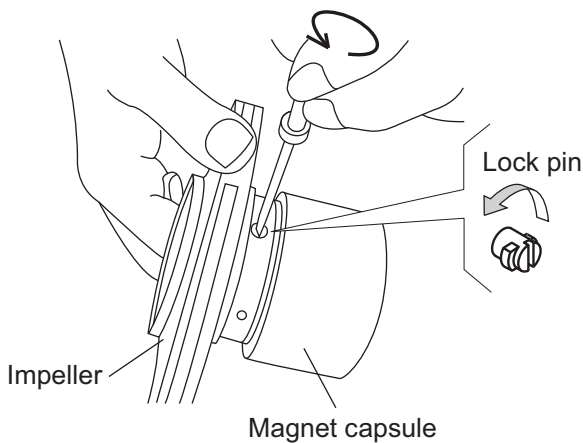
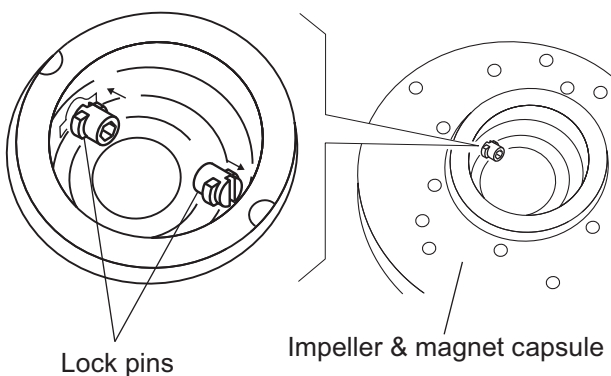

Turn the lock pins 90 degrees anticlockwise using a flathead screwdriver and then push it off. If it is hard to push it off, slightly tap the end of driver handle.

The lock pins can also be turned by using the 4mm hex. wrench from the inside of magnet capsule assembly. In this case turn the wrench clockwise. The lock pins will be damaged if it is turned in reverse direction. After unscrewing the pins, push it off from the outside by using a bar.

Maintenance

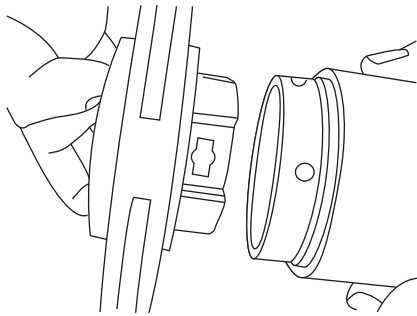

After the lock pins are removed, detach the impeller unit from the magnet capsule assembly by slightly tapping the back of the impeller unit with a plastic hammer. If the impeller unit is hardly removed, warm it in hot water (approx. 90°C) for 5 minutes and tap it slightly, again. Be careful not to scald in hot water.

To remove the bearing from the magnet capsule assembly, first separate the impeller unit from the assembly. Then use a hand press with plastic extruding bar to extrude the bearing toward impeller connection side.

To insert the bearing into the magnet capsule, reverse this procedure. If the bearing can not be removed, warm the magnet capsule assembly with hot water (about 90°C) for 5 minutes and try again. Be careful not to be scalded.

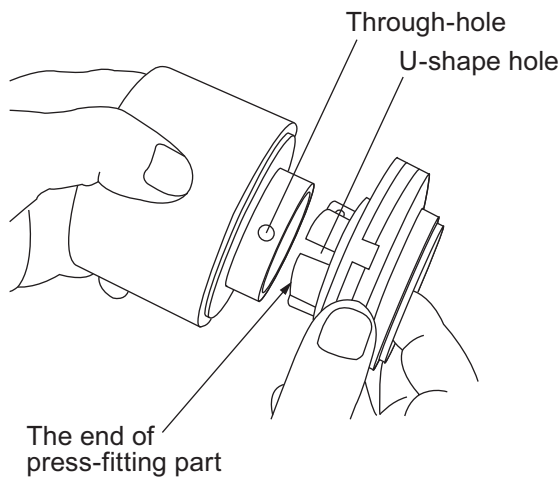

■ Assembly

1. *Mount the impeller unit to the magnet capsule assembly.*

a. MXM220/ 221/ 441/ 442

Press and fit the impeller unit into the magnet capsule assembly with the U-shape hole under the through hole.

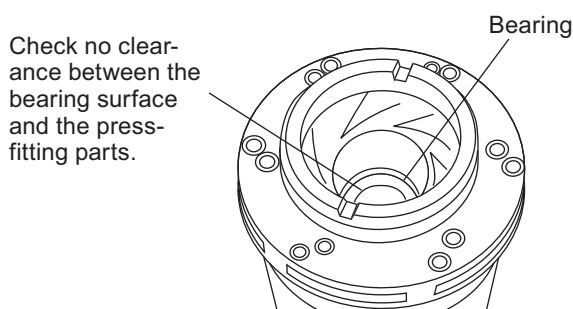

Check that the end of press-fitting parts has come at a bearing surface. If the impeller unit can not be fitted to the magnet capsule assembly, warm it in hot water (about 90°C for 5 minutes) for softening. Be careful not to get scalded with hot water.

Maintenance

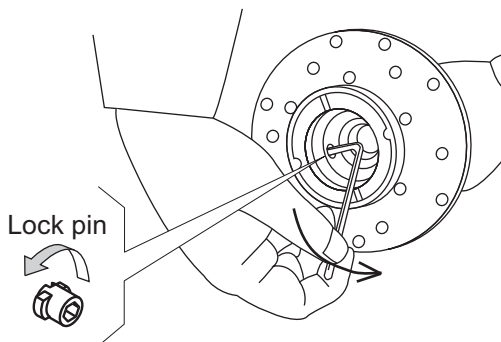
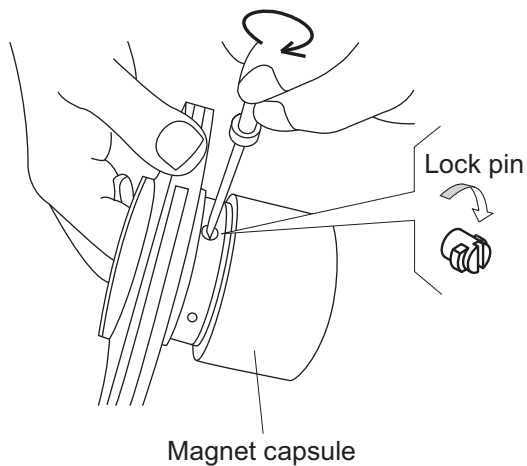
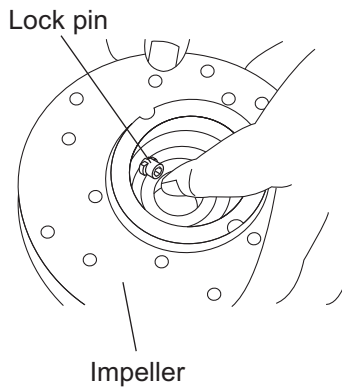
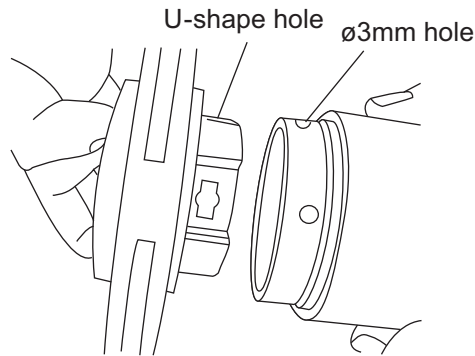

b. MXM542/ 543/ 545

Attach the impeller unit to the magnet capsule assembly.

The mating surface on the assembly has two holes. The large hole (Stepped holes with 6mm at outer dia. & 12mm at inner dia) is for the lock pins and the small hole (3mm dia.) is for cooling. Press the impeller unit into the magnet capsule assembly with U-shape hole under the smaller hole (3 mm dia.). If it is difficult to insert them, warm the magnet capsule assembly in the hot water (approx. 90°C) for 5 minutes. Be careful not to scald at this time.

After fitting the impeller unit, push the lock pins into the lock pin holes from the inside as far as it will go.

Use a flat-head screwdriver to turn the pins 90 degrees clockwise from the outside while holding the pins from the inside. Once it clicks, the impeller unit is secured.

If the screw groove is deformed and can not be used, the pin can be turned from the inside with a 4mm hex. wrench. In this case pay attention to turn the wrench anticlockwise. The lock pin may be broken if it is turned in reverse.

Maintenance

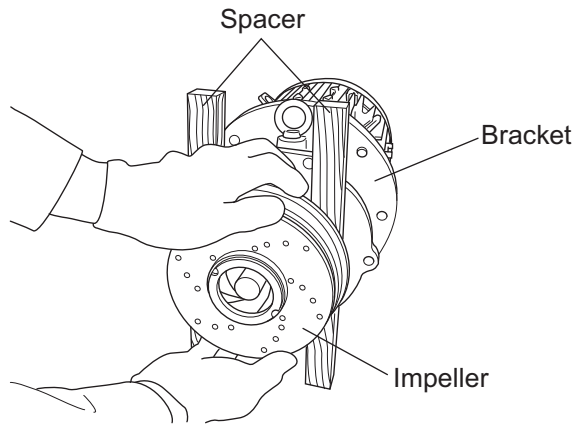

2. Insert the magnet capsule assembly plus the impeller unit into the rear casing slowly.
Do not allow iron pieces to adhere to the magnet capsule assembly.
3. Mount the rear casing to the bracket with the magnet capsule assembly in it.

⚠ CAUTION

Magnet force is very powerful. Apply plastic or wooden spacers between the rear casing and the frame so as not to catch the fingers.

4. Fit O ring to the front casing. Check that sealing surfaces are free of dust or scratches. Make sure that O ring is in place and will not be out of the groove.

⚠ CAUTION

Replace O ring and gasket with new ones at each time of replacement. Reusing old O ring and gasket could reduce seal performance and result in leakage.

5. Mount the front casing to the motor bracket.
Tighten the hex. socket bolts diagonally and equally. Tightening torque is shown below.

Model	Tightening torque	Bolt size
MXM220/221	12.5N•m	M8
MXM441/442/542/543/545	24.5N•m	M10

⚠ CAUTION

The hex. socket bolt length differs with each position. Be sure to select proper bolts to each position. Otherwise, leak or other failure may result.

6. Hand tighten the drain cap and check it is secured. Use a tightening tool such as pliers to give it further torque, especially before operation with a high-temperature or a high-pressure liquid. Be careful not to tighten it too much, or the plastic cap may break.

Maintenance

4. Spare & Wear parts

Appropriate spare parts are necessary for a long period of continuous operation. We recommend that wear parts be always in stock. Place an order for spares with the following information.

1. Part names and part number (See the diagram below.)
2. Pump model identification code and manufacturing number (See pump nameplate.)
3. Drawing number if you have our approval drawing

No.	Part names		Materials	Selection codes					
				MXM220	MXM221	MXM441	MXM442	MXM542/543	MXM545
210	Spindle	CF	High purity alumina ceramic	MXM0174			MXM0001		
		KK	SiC	MXM0175			MXM0002		
310	Bearing	CF	High density carbon	MXM0183			MXM0016		
		KK	SiC	MXM0185			MXM0017		
210 + 310	Bearing, Spindle set	FF	High purity alumina ceramic	MXM0365			MXM0371		
314.2	Mouth ring	CF/FF	Filled PTFE	MXM204			MXM0063		
		KK	SiC	MXM205			MXM0064		
314.3	Rear thrust		MXM22/44: CFRETFE MXM54: CFRPFA	MXM0176			MXM0003		
859 + 310	Magnet capsule assembly	CF	CFRETFE + High density carbon	MXM0177	MXM0178	MXM0267	MXM0004	MXM0012	
		KK	CFRETFE + SiC	MXM0181	MXM0182	MXM0269	MXM0005	MXM0013	
859 + 310 + 210	Magnet capsule assembly, spindle set	FF	CFRETFE + Highly purity alumina ceramic	MXM0361	MXM0362	MXM0363	MXM0368	MXM0369	
400.1	O ring		FKM	MXM0218		MXM0305		MXM0006	
			EPDM	MXM0220		MXM0306		MXM0007	
			AFLAS®	MXM0221		MXM0307		MXM0008	
			DAI-EL PERFLUOR®	MXM0217		MXM0308		MXM0014	
400.2	Gasket		FKM	MXM0009					
			EPDM	MXM0010					
			AFLAS®	MXM0011					
			DAI-EL PERFLUOR®	MXM0015					

Maintenance

MXM22

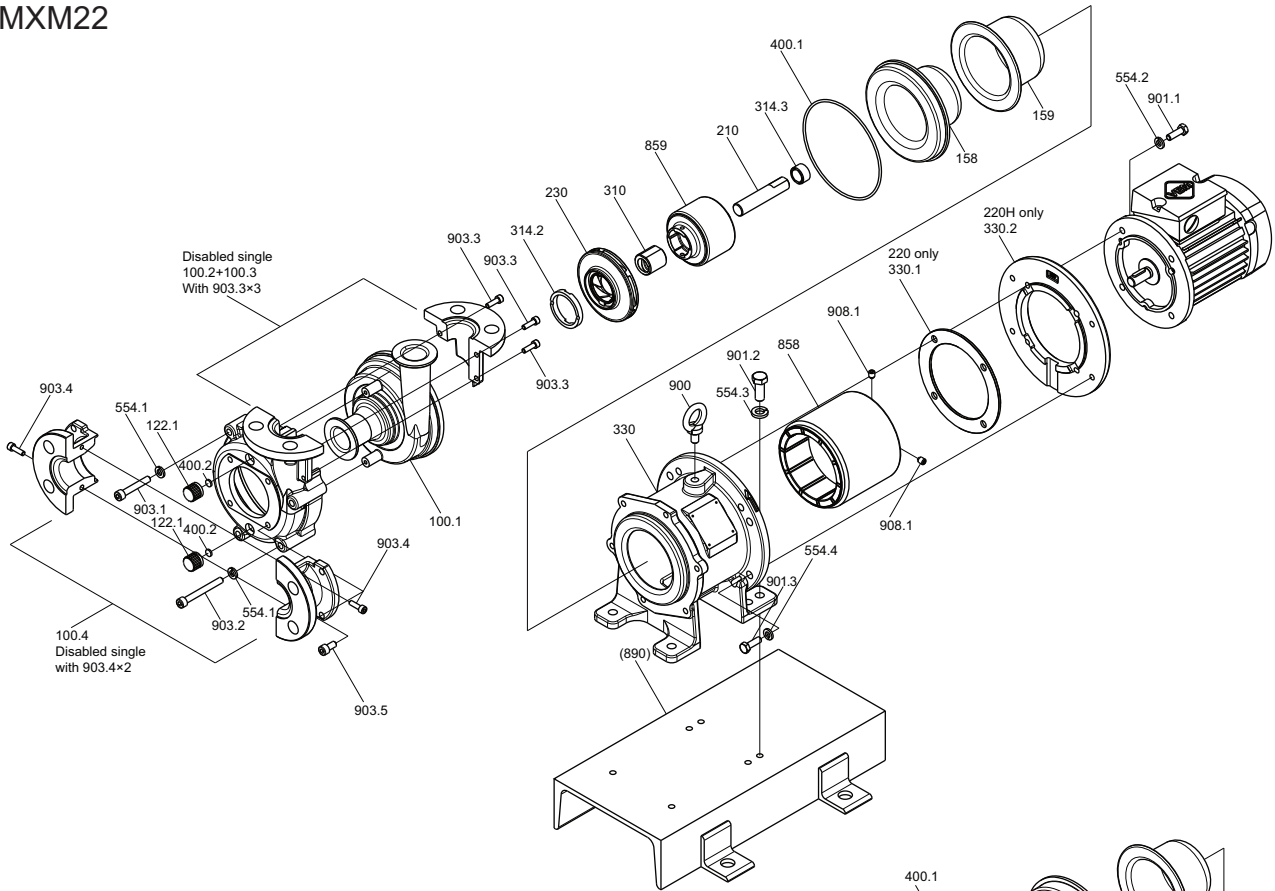

MXM44

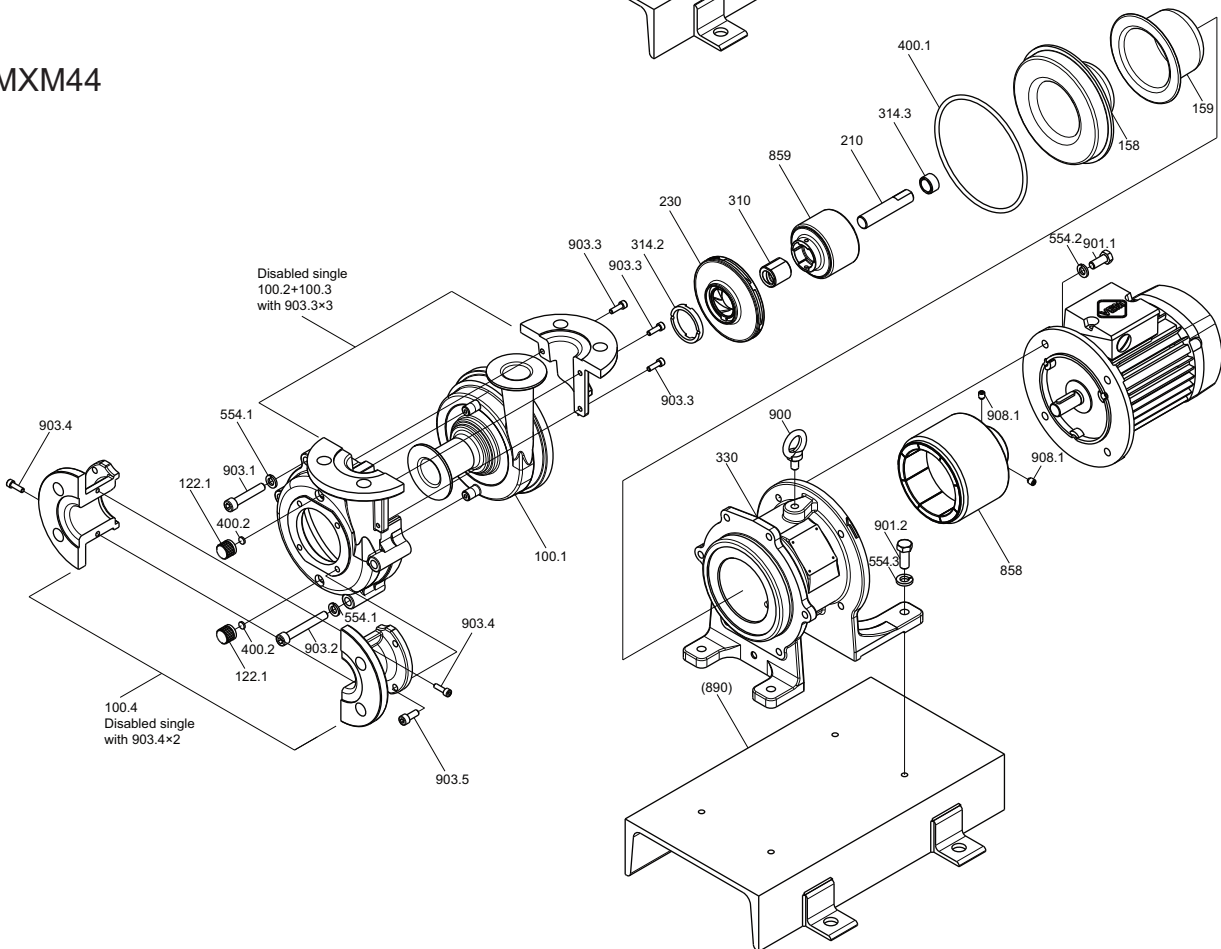

Maintenance

MXM54

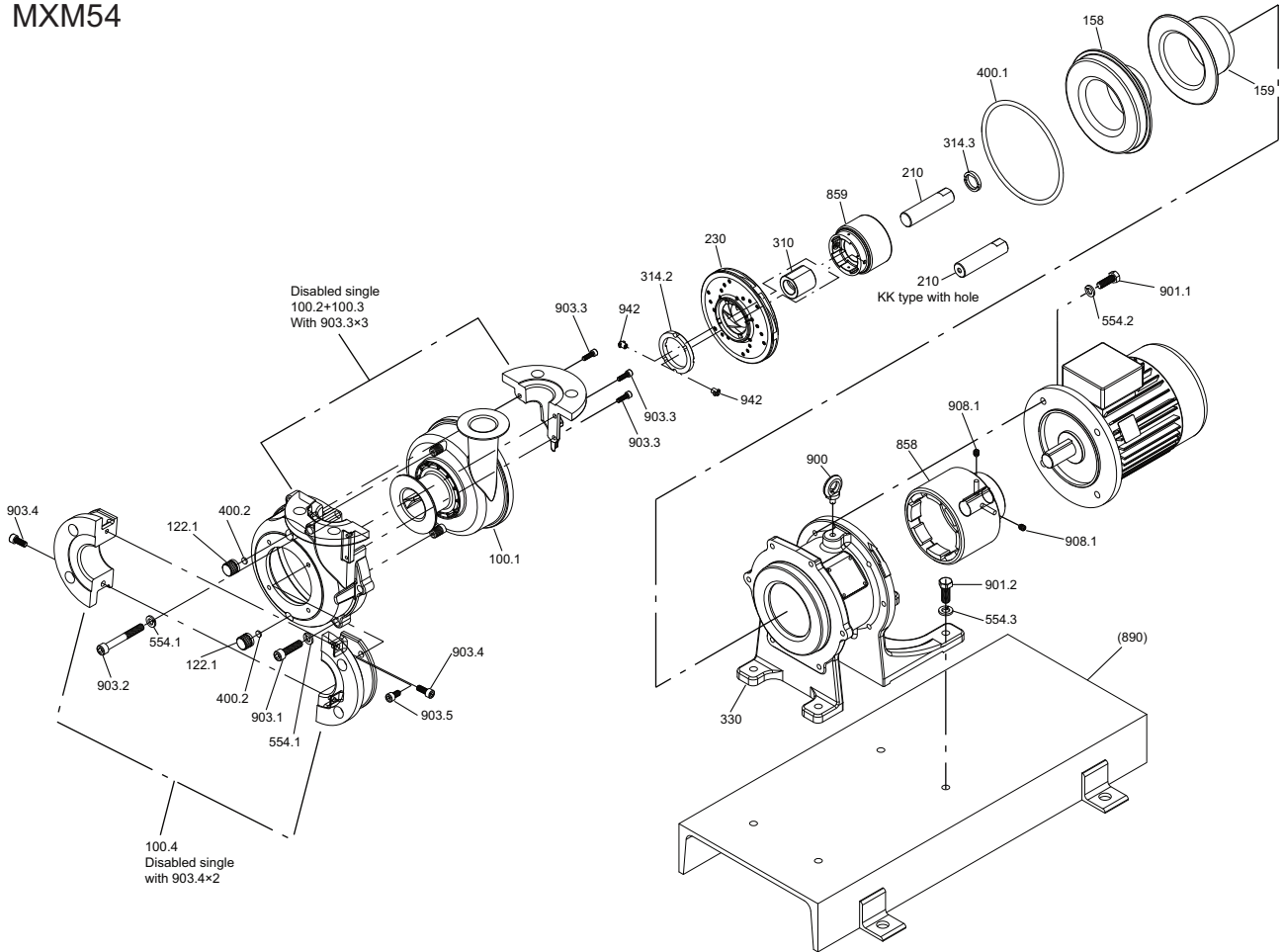



()Country codes
IWAKI CO.,LTD. 6-6 Kanda-Sudacho 2-chome Chiyoda-ku Tokyo 101-8558 Japan
 TEL:(81)3 3254 2935 FAX:3 3252 8892(<http://www.iwakupumps.jp>)

Australia	IWAKI Pumps Australia Pty. Ltd.	TEL : (61)2 9899 2411	FAX : 2 9899 2421	Italy	IWAKI Italia S.R.L.	TEL : (39)02 990 3931	FAX : 02 990 42888
Austria	IWAKI (Austria) GmbH	TEL : (43)2236 33469	FAX : 2236 33469	Korea	IWAKI Korea Co.,Ltd.	TEL : (82)2 2630 4800	FAX : 2 2630 4801
Belgium	IWAKI Belgium n.v.	TEL : (32)1367 0200	FAX : 1367 2030	Malaysia	IWAKIm Sdn. Bhd.	TEL : (60)3 7803 8807	FAX : 3 7803 4800
China	IWAKI Pumps (Shanghai) Co., Ltd.	TEL : (86)21 6272 7502	FAX : 21 6272 6929	Norway	IWAKI Norge AS	TEL : (47)66 81 1660	FAX : 66 81 16 61
China	IWAKI Pumps (Guandong) Co., Ltd.	TEL : (86)750 3866228	FAX : 750 3866278	Singapore	IWAKI Singapore Pte. Ltd.	TEL : (65)6316 2028	FAX : 6316 3221
China	GFTZIWAKI Engineering & Trading (Guangzhou)	TEL : (86)20 8435 0603	FAX : 20 8435 9181	Spain	IWAKI Iberica Pumps, S.A.	TEL : (34)943 630030	FAX : 943 628799
China	GFTZIWAKI Engineering & Trading (Beijing)	TEL : (86)10 6442 7713	FAX : 10 6442 7712	Sweden	IWAKI Sverige AB	TEL : (46)8 511 72900	FAX : 8 511 72922
Denmark	IWAKI Nordic A/S	TEL : (45)48 24 2345	FAX : 48 24 2346	Switzerland	IWAKI (Schweiz) AG	TEL : (41)26 674 9300	FAX : 26 674 9302
Finland	IWAKI Suomi Oy	TEL : (358)9 2745810	FAX : 9 2742715	Taiwan	IWAKI Pumps Taiwan Co., Ltd.	TEL : (886)2 8227 6900	FAX : 2 8227 6818
France	IWAKI France S.A.	TEL : (33)1 6963 3370	FAX : 1 64 49 92 73	Taiwan	IWAKIPumpsTaiwan (Hsin-chu) Co., Ltd.	TEL : (886)3 573 5797	FAX : (886)3 573 5798
Germany	IWAKI EUROPE GmbH	TEL : (49)2154 9254 0	FAX : 2154 9254 48	Thailand	IWAKI (Thailand) Co.,Ltd.	TEL : (66)2 322 2471	FAX : 2 322 2477
Holland	IWAKI EUROPE NL Branch	TEL : (31)547 293 160	FAX : 547 292 332	U.K.	IWAKI Pumps (UK) LTD.	TEL : (44)1743 231363	FAX : 1743 366507
Hong Kong	IWAKI Pumps Co., Ltd.	TEL : (852)2 607 1168	FAX : 2 607 1000	U.S.A.	IWAKI AMERICA Inc.	TEL : (1)508 429 1440	FAX : 508 429 1386
Indonesia	IWAKI Singapore (Indonesia Branch)	TEL : (62)21 690 6606	FAX : 21 690 6612	Vietnam	IWAKI pumps Vietnam Co.,Ltd.	TEL : (84)613 933456	FAX : 613 933399